



Cambridge International Examinations
Cambridge International General Certificate of Secondary Education

CANDIDATE
NAME

CENTRE
NUMBER

--	--	--	--	--

CANDIDATE
NUMBER

--	--	--	--



CO-ORDINATED SCIENCES

0654/23

Paper 2 (Core)

October/November 2016

2 hours

Candidates answer on the Question Paper.

No Additional Materials are required.

READ THESE INSTRUCTIONS FIRST

Write your Centre number, candidate number and name on all the work you hand in.

Write in dark blue or black pen.

You may use an HB pencil for any diagrams or graphs.

Do not use staples, paper clips, glue or correction fluid.

DO NOT WRITE IN ANY BARCODES.

Answer **all** questions.

Electronic calculators may be used.

You may lose marks if you do not show your working or if you do not use appropriate units.

A copy of the Periodic Table is printed on page 28.

At the end of the examination, fasten all your work securely together.

The number of marks is given in brackets [] at the end of each question or part question.

This document consists of **28** printed pages.

1 Fig. 1.1 shows a dead mouse lying on some grass in a field. The mouse is decaying.

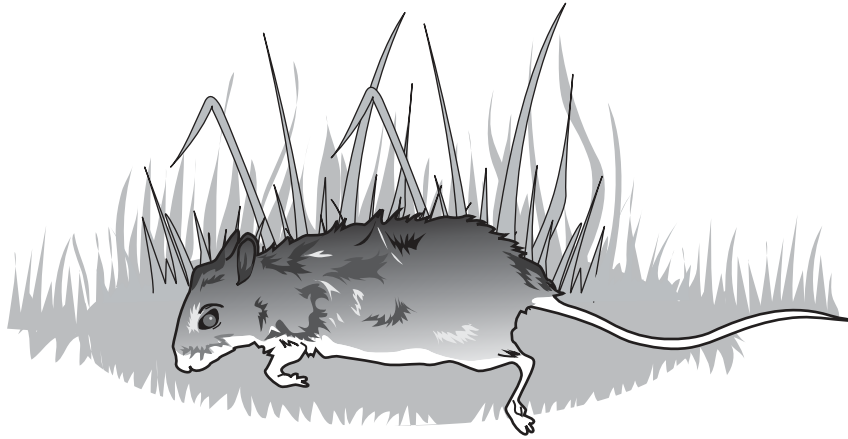

Fig. 1.1

During the process of decay, mineral ions, such as nitrates, are produced.

(a) The presence of extra nitrates in the soil causes the grass near the mouse to grow taller than in the rest of the field.

(i) Explain why nitrates are important for the growth of grass.

.....
..... [1]

(ii) Name **one** other mineral ion, apart from nitrate, that is important for the growth of grass, and state why it is important.

ion

importance

..... [2]

(b) Name another substance, **not** a mineral ion, that is produced during the decay of the mouse.

..... [1]

(c) Explain why the grass underneath the mouse's body **cannot** grow well.

.....
.....
..... [2]

(d) A living mouse feeds on grass seeds. The mouse is eaten by an owl.

(i) In the space, draw a food chain to show these relationships.

[2]

(ii) Name the consumers in this food chain.

.....

..... [1]

- 2 (a) Fig. 2.1 shows a pie chart of the composition of a sample of air.

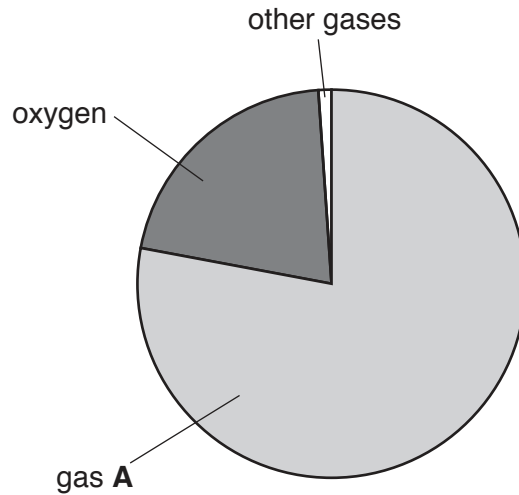

Fig. 2.1

- (i) Name gas **A** and state the usual percentage of this gas in clean air.

name of gas **A**

percentage%

[2]

- (ii) Name **one** gas present in the section labelled *other gases* for a sample of clean air.

..... [1]

- (iii) In a sample of air collected from a large city, carbon monoxide and nitrogen oxides are also present.

Suggest why these gases are present.

.....

.....

..... [2]

- (b) The water supply for a large city is treated with chlorine.

Explain why this is done.

.....

.....

..... [2]

- (c) Compound **D** can also be used to treat water. Table 2.1 contains information about compound **D**.

Table 2.1

number of chlorine atoms in one molecule of D	1
number of oxygen atoms in one molecule of D	2
melting point of D /°C	-59
boiling point of D /°C	+11

- (i) Compound **D** contains only the elements chlorine and oxygen. State the formula of compound **D**.

..... [2]

- (ii) State and explain whether compound **D** is a solid, liquid or gas at room temperature, 20°C.

state of compound **D** at 20°C

explanation

.....

.....

[2]

3 (a) A train travels from station **A** to station **B**.

Fig. 3.1 shows a speed/time graph for this journey.

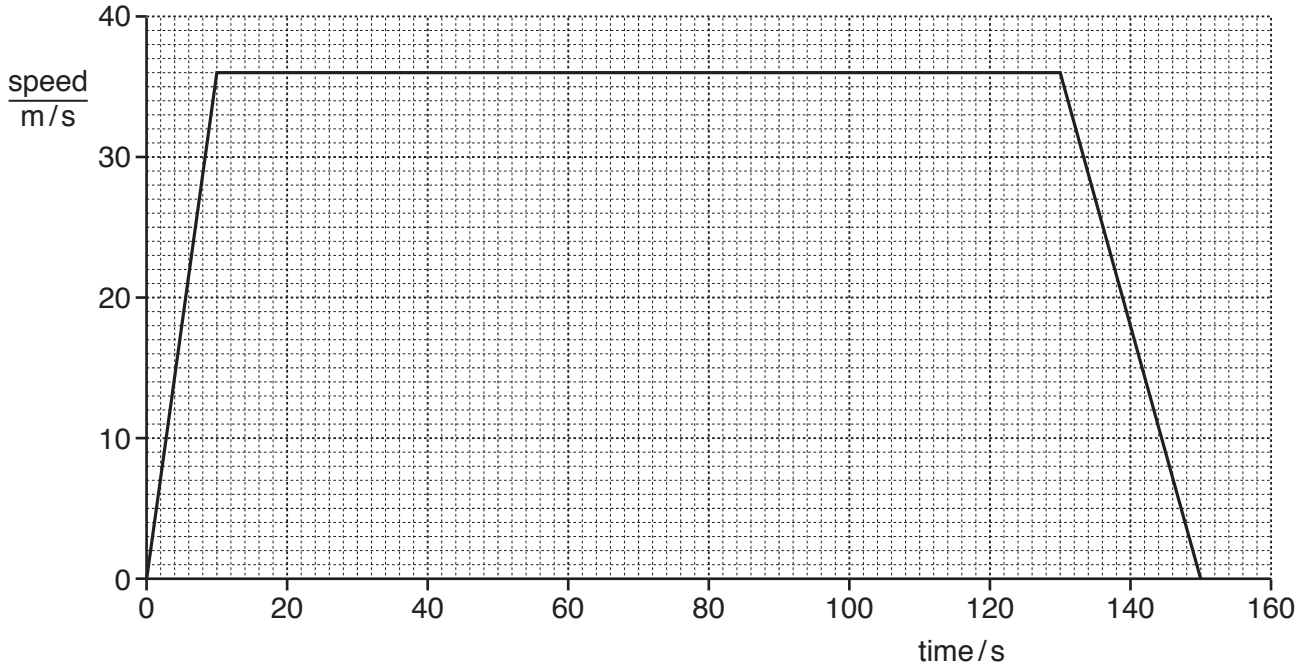

Fig. 3.1

(i) The train starts from station **A** and travels without stopping until it reaches station **B**.

Label the time axis with the letters **A** and **B** to show the times when the train is at station **A** and arrives at station **B** on this journey. [1]

(ii) State the maximum speed reached by the train.

.....m/s [1]

(iii) Calculate the distance travelled while travelling at the maximum speed.

Show your working.

distance = m [2]

(iv) When the train slows down, it loses kinetic energy.

State what happens to most of the kinetic energy that is lost.

..... [1]

- (b) The train is very noisy. It emits a sound with a frequency of 1500 Hz.

A passenger on the train can hear the sound because the frequency is within the human audible frequency range.

State the normal audible frequency range for an adult human.

from Hz to Hz [1]

- (c) The train track is made of lengths of steel rails with small gaps between them. This is shown in Fig. 3.2.

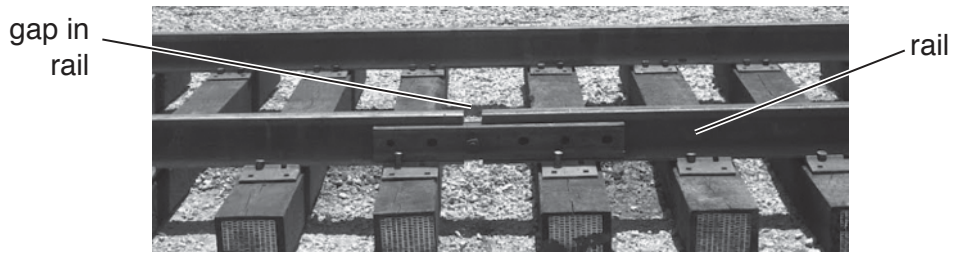

Fig. 3.2

Suggest the reason for leaving these gaps between the rails.

.....

 [2]

- (d) Each rail is made from a block of steel of volume 512000 cm^3 .

The density of steel is 8.0 g/cm^3 .

- (i) Calculate the mass of a steel rail.

State the formula you use and show your working.

formula

working

mass = g [2]

- (ii) The cross-sectional area of a steel rail is 160 cm^2 , as shown in Fig. 3.3. The volume of the rail is 512000 cm^3 .

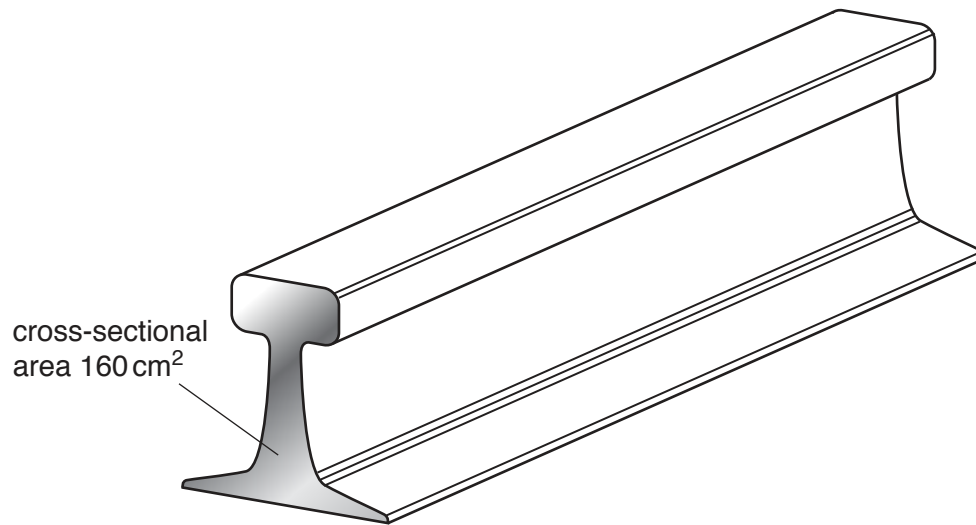

Fig. 3.3

Calculate the length of the steel rail.

Show your working.

length =cm [2]

- (iii) The steel rail on the Earth has a weight as well as a mass.

State the unit for weight [1]

4 (a) Fig. 4.1 shows a flower in longitudinal section.

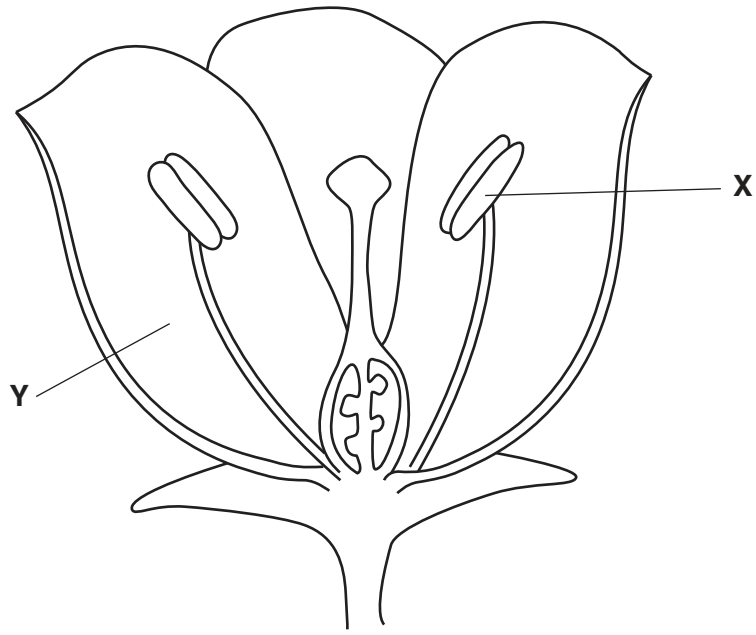

Fig. 4.1

(i) Suggest how this flower is pollinated.

..... [1]

(ii) State what will be found inside the part of the flower labelled X.

..... [1]

(iii) The part labelled Y is brightly coloured. Suggest why this bright colouring is important.

.....
..... [1]

- (b) A student investigates the effect of temperature on the germination of seeds. He has ten packets and each packet contains 20 seeds.

The student incubates the seeds from each packet at a different temperature. After one week, he records how many seeds from each packet have germinated.

His results are shown in Table 4.1.

Table 4.1

temperature/°C	number of seeds that germinated after one week
5	0
10	2
15	14
20	20
25	19
30	17
35	3
40	0
45	0
50	0

- (i) Apart from temperature, suggest **one** environmental condition that should be controlled in this experiment.

..... [1]

- (ii) Calculate the percentage of seeds that germinated at 25°C.

..... %
[1]

(iii) From the results in Table 4.1, state what can be concluded about the effect of temperature on the germination of these seeds.

.....
.....
..... [2]

(iv) Suggest **one** reason why temperature affects the rate of germination, as shown in Table 4.1.

.....
..... [1]

- 5 (a) A student is asked to safely produce some hydrogen.

Fig. 5.1 shows the apparatus and a choice of elements available.

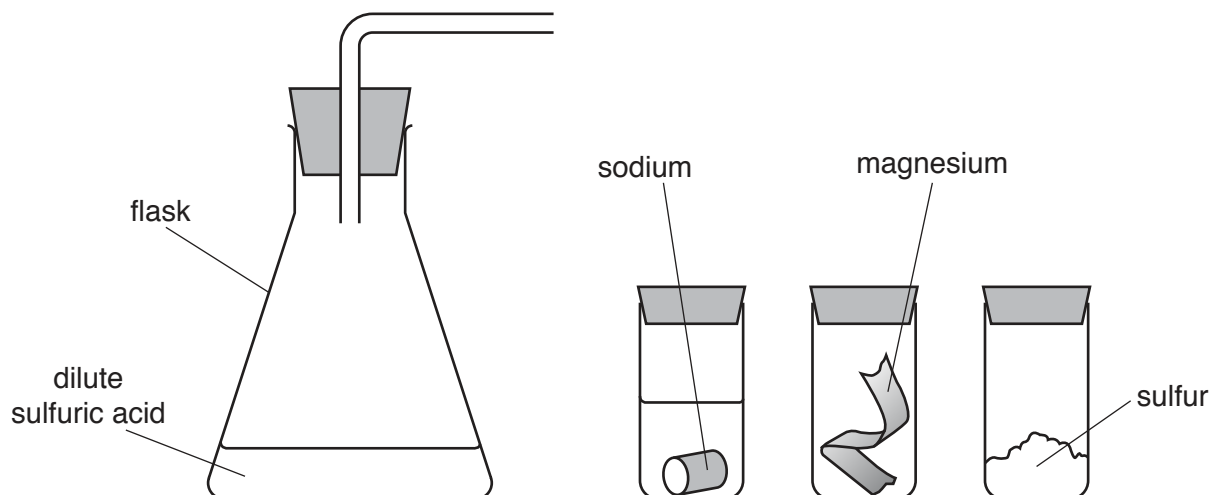

Fig. 5.1

The student correctly decides to add magnesium to the acid to produce hydrogen safely.

Explain why the other two elements are unsuitable for this task.

sodium

.....

sulfur

.....

[2]

- (b) The hydrogen produced is burnt in air. A cold metal plate is held above the burning hydrogen, as shown in Fig. 5.2.

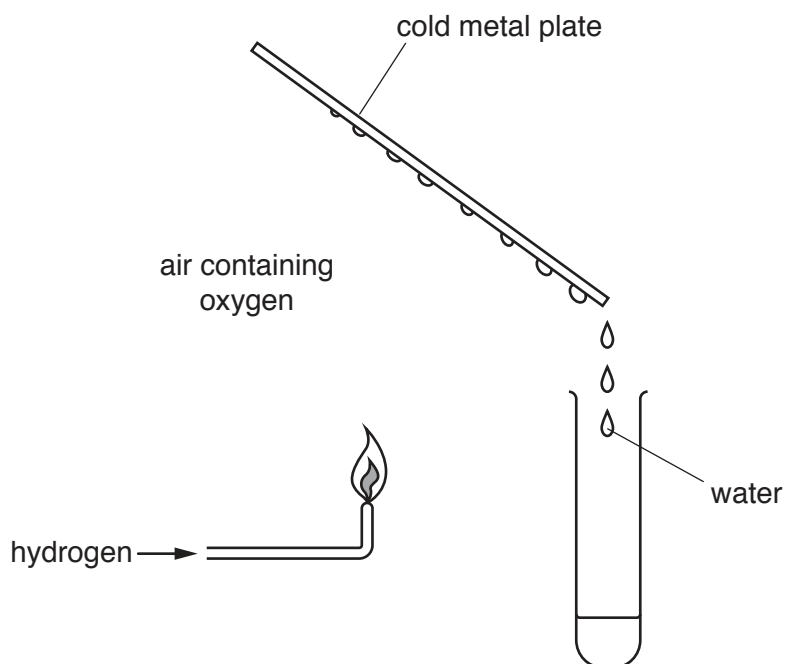

Fig. 5.2

- (i) Water condenses on the metal plate.

Describe a chemical test for water. Give the positive result.

test

result

[2]

- (ii) Explain why the burning of hydrogen is an example of an oxidation reaction.

.....

.....

..... [2]

- (iii) Identify **one** physical change which is occurring in Fig. 5.2.

.....

..... [1]

- 6 (a) Electricity is generated in a nuclear power station by nuclear fission. Nuclear fission releases thermal energy.

Describe how the thermal energy released is transferred into electrical energy in a power station.

.....

 [4]

- (b) Workers in a nuclear power station are monitored to check their exposure to radiation.

(i) Suggest **one** method of monitoring the workers' exposure to radiation.

.....
 [1]

(ii) Describe **one** hazard of ionising radiation to living things.

.....
 [1]

- (c) α -particles, β -particles and γ -rays are three radioactive emissions.

Place the three emissions in order of their ionising ability, with the most ionising first.

..... [1]
 most ionising least ionising

- (d) γ -rays are part of the electromagnetic spectrum.

Fig. 6.1 shows an incomplete electromagnetic spectrum.

(i) Place γ -rays in their correct position on Fig. 6.1.

	X-rays		visible light		microwaves	
--	--------	--	---------------	--	------------	--

Fig. 6.1

(ii) State **one** property that is the same for all electromagnetic waves.

..... [1]

7 White rabbits have no pigmentation in their fur. This is a genetic condition caused by a recessive allele. Grey rabbits have a dominant allele for grey fur.

(a) Two grey rabbits are mated. The offspring include both white and grey rabbits.

(i) Complete the genetic diagram in Fig. 7.1 to show how this could occur.

G is the allele for grey and **g** is the allele for white.

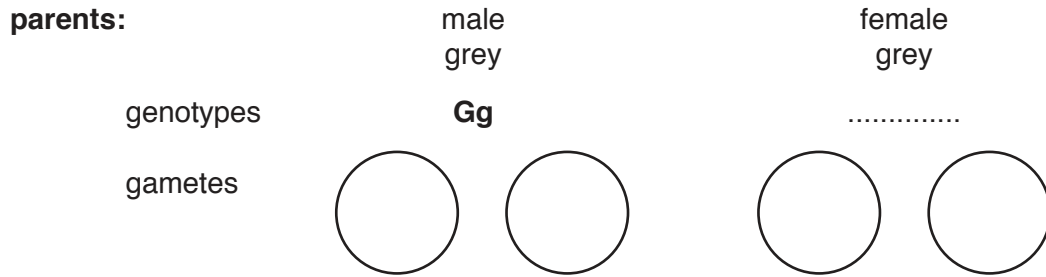

offspring:

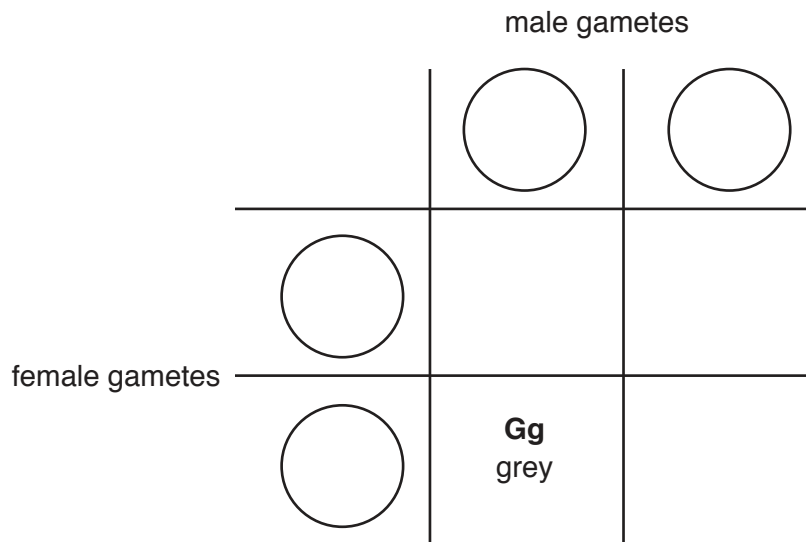

Fig. 7.1

[4]

(ii) State the probability of the **first** rabbit in the offspring being white.

..... [1]

(b) State the correct terms to describe

(i) an allele that prevents a recessive allele from being expressed, such as the allele **G** for grey in part (a),

..... [1]

(ii) the physical or other features of an individual, such as being grey or white, that result from their genotype and their environment,

..... [1]

(iii) the genotype of an individual where there are two different alleles, such as **Gg**.

..... [1]

8 (a) (i) Name the collection of metals in the Periodic Table that includes copper.

..... [1]

(ii) Some properties, **A** to **F**, of copper are listed.

A can be used as a catalyst

B forms some coloured compounds

C is a good conductor of electricity

D is a good conductor of thermal energy

E is malleable

F is non-magnetic

State the **two** letters of the properties listed, which do **not** describe metals in Group I in the Periodic Table.

.....

.....

[2]

(b) Fig. 8.1 shows a method of producing a sample of copper chloride crystals.

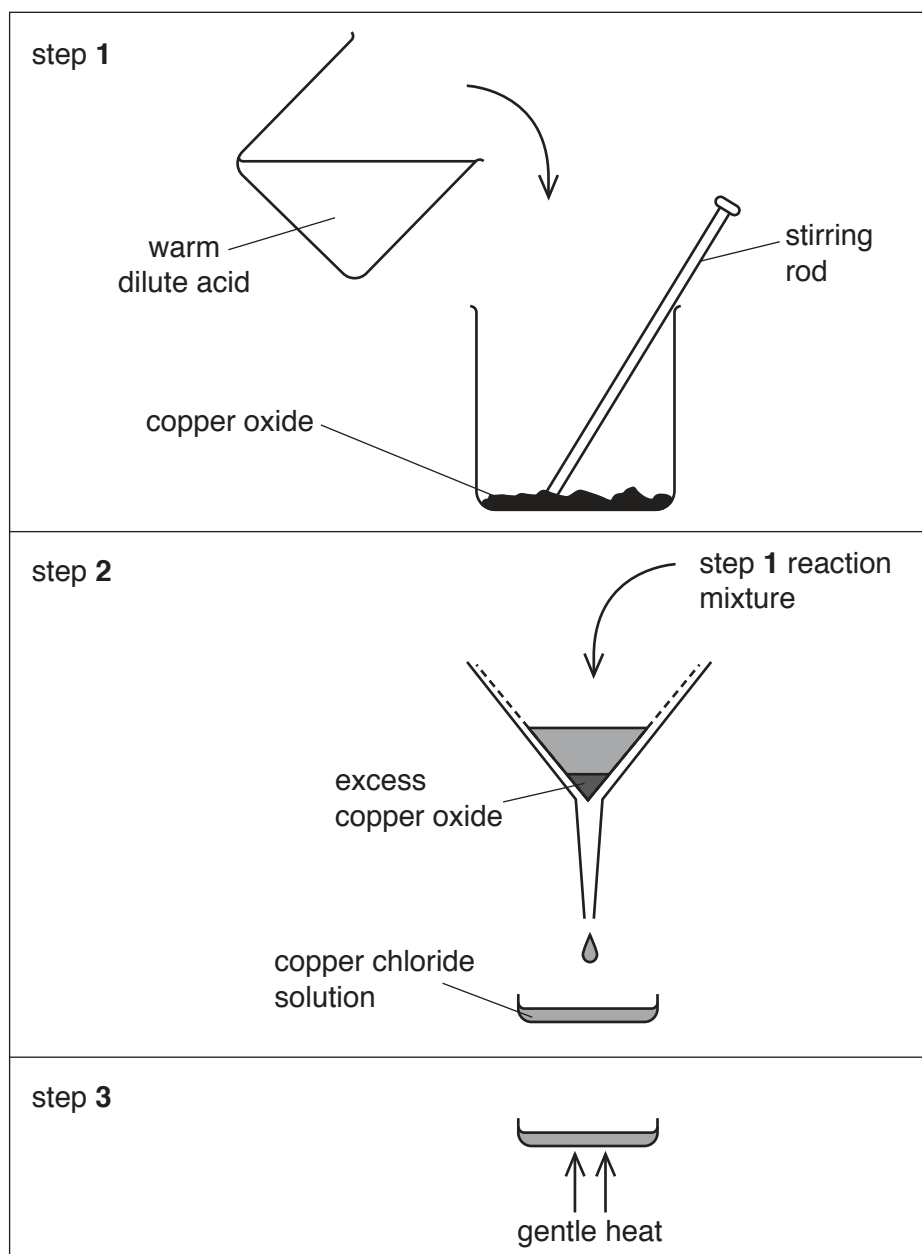

Fig. 8.1

(i) Name the processes shown in steps 2 and 3.

step 2

step 3

[2]

(ii) Complete the **word** equation for the reaction in step 1.

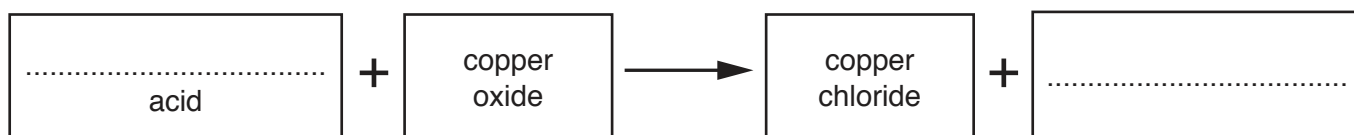

[2]

(c) Fig. 8.2 shows laboratory apparatus used to electroplate steel.

The piece of steel becomes covered by a thin layer of zinc.

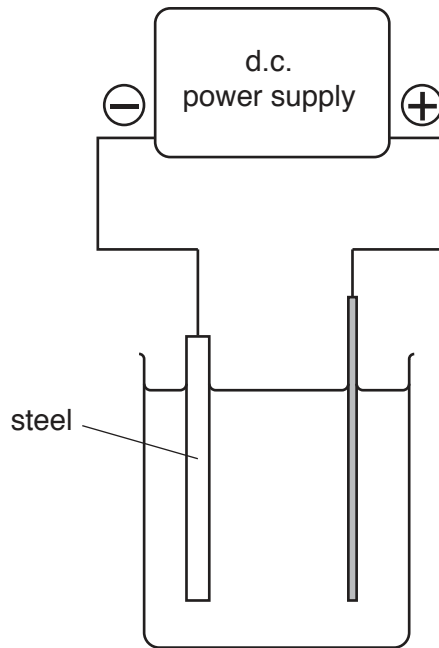

Fig. 8.2

(i) On Fig. 8.2 label the electrolyte. [1]

(ii) Suggest a suitable material to use as the anode.

..... [1]

(iii) Explain why zinc-plated steel will prevent rusting.

.....

 [2]

- 9 (a) (i) A car travels along a road. During the journey the temperature of the air in the tyres increases by 25°C . The volume of air in the tyres remains the same.

Explain in terms of particles why the pressure of the air in the tyres increases.

.....

.....

.....

..... [2]

- (ii) State **one** variable, other than temperature, that affects the pressure exerted on the road by a car.

..... [1]

- (b) Fig. 9.1 shows a circuit diagram for lamps in a car. A 12V battery is connected to the four lamps.

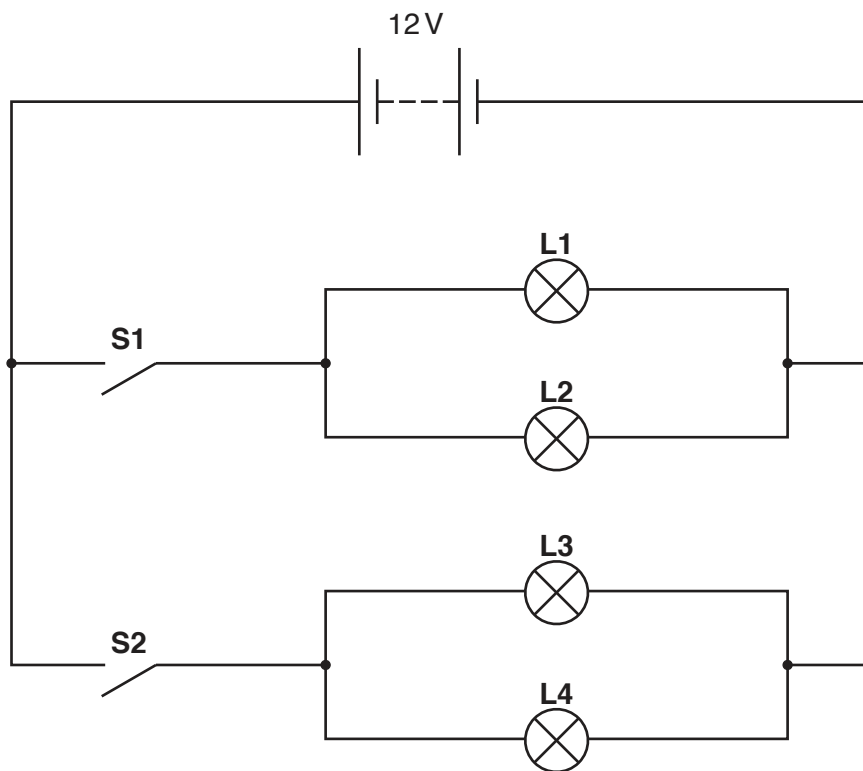

Fig. 9.1

- (i) Both switches are open. State which lamps are lit when switch **S1** is now closed.

..... [1]

- (ii) Lamps **L1** and **L2** are identical and each has a resistance of $3\ \Omega$ when lit.

From the list of resistance values below, select the correct value for the combined resistance of **L1** and **L2** in parallel. Circle your choice.

1.5 Ω

3 Ω

6 Ω

9 Ω

Explain your answer.

.....
..... [2]

- (iii) Lamps **L3** and **L4** are identical lamps and each has a resistance of $24\ \Omega$ when lit.

When switch **S2** is closed, calculate the current in lamp **L3**.

State the formula you use and show your working.

formula

working

current = A [2]

- (c) The bodywork of a car is usually made from steel. The bodywork of some cars is made from aluminium.

Suggest a simple way of deciding whether the bodywork is made from steel or aluminium.

Explain your answer.

.....
.....
..... [2]

10 Fig. 10.1 shows some parts of the human alimentary canal and breathing system.

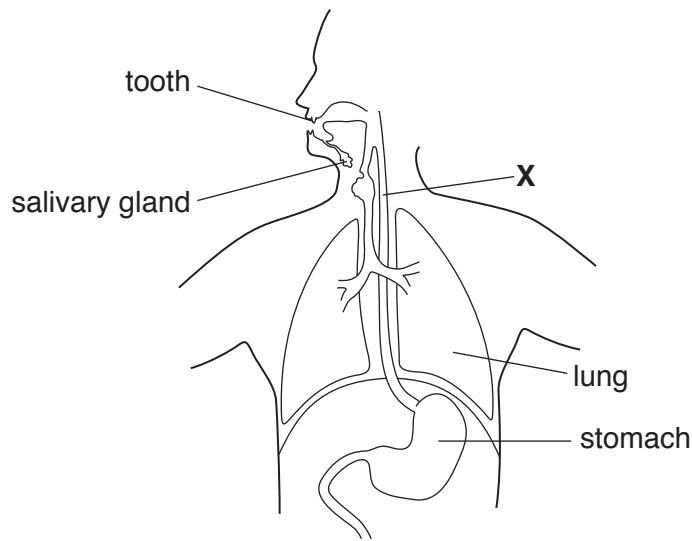

Fig. 10.1

(a) Name the part labelled X and state its function.

X

function

[2]

(b) Name the enzyme secreted by the salivary glands, and state the function of this enzyme.

enzyme

function

[2]

(c) On Fig. 10.1, use a label line and the letter I to show where the process of ingestion occurs. [1]

(d) Describe how the teeth are important in the function of the digestive system.

.....

.....

.....

..... [2]

- 11 (a) Table 11.1 shows the numbers of protons, neutrons and electrons in a carbon atom and in a hydrogen atom.

Table 11.1

atom	number of protons	number of neutrons	number of electrons
carbon	6	6	6
hydrogen	1	0	1

- (i) Explain why a carbon atom does **not** have an overall electrical charge.

.....

 [2]

- (ii) State the nucleon number of the atom of hydrogen in Table 11.1.

..... [1]

- (b) Methane contains only carbon and hydrogen atoms bonded together.

- (i) State the general name of compounds containing only carbon and hydrogen atoms.

..... [1]

- (ii) Complete the diagram to show the structure of a molecule of methane.

H —

[2]

(c) Fig. 11.1 shows the structure of a molecule of ethene.

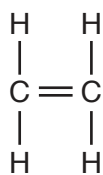

Fig. 11.1

Complete the right hand column in Table 11.2 with a tick (✓) if the statement describes ethene or a cross (X) if it does not.

Table 11.2

It burns to form carbon dioxide and water.	
It is a saturated compound.	
It is produced in industry by cracking.	
It turns orange bromine solution colourless.	

[2]

(d) When pure ethene gas is heated under pressure with a catalyst, a white solid is produced.

(i) State the type of chemical reaction that occurs and name the white solid.

type of reaction

name of white solid

[2]

(ii) Describe what happens to the molecules of ethene during the reaction that produces the white solid.

.....

..... [1]

- 12 (a) State the method of thermal energy transfer that occurs when infra-red radiation travels from the Sun to the Earth.

..... [1]

- (b) Fig. 12.1 represents an infra-red wave.

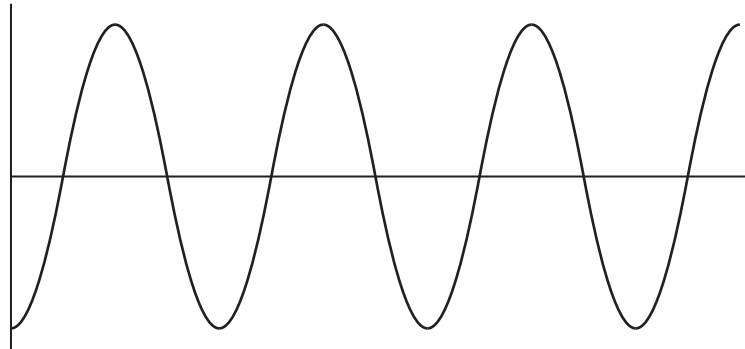

Fig. 12.1

On Fig. 12.1, use double headed arrows (\leftrightarrow or \updownarrow) to

- (i) label **one** wavelength and mark it with a **W**, [1]
- (ii) label the amplitude of the wave and mark it with an **A**. [1]

- (c) Fig. 12.2 shows a ray of white light passing into a prism.

Complete Fig. 12.2 to show the path of the light as it passes through and leaves the prism to form a spectrum on the screen.

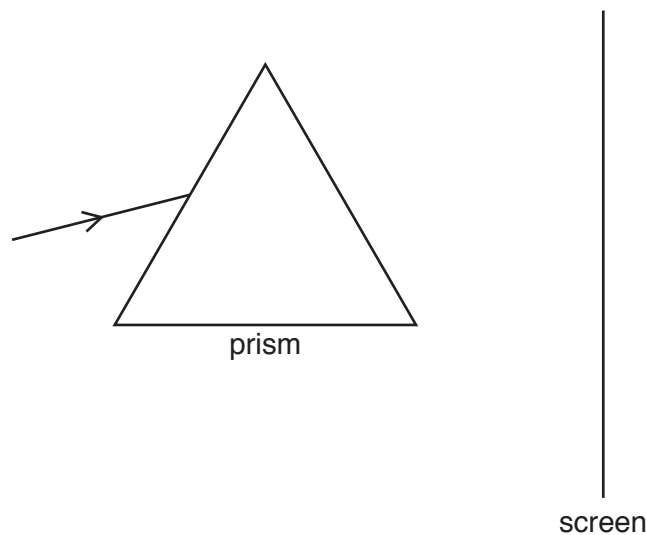

Fig. 12.2

[2]

- (d) The nuclear reactions that take place in the Sun produce sound energy.

Explain why we cannot hear this sound on Earth.

.....
 [1]

- (e) The Moon can be viewed with a telescope. Telescopes use lenses.

Fig. 12.3 shows rays of light passing through a lens. There is an object **O** on the left of the lens. An image **I** is formed on the right of the lens.

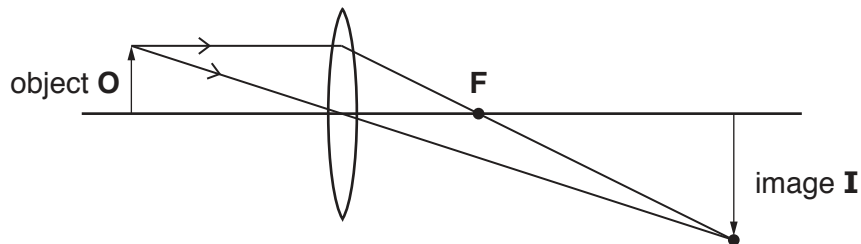

Fig. 12.3

- (i) State the name of point **F** in Fig. 12.3.

..... [1]

- (ii) The following words can be used to describe the image formed by a lens.

diminished **enlarged** **inverted** **upright**

Circle the **two** words that describe the image in Fig. 12.3.

[1]

13 (a) Write the **word** equation for photosynthesis.

..... [2]

(b) Fig. 13.1 shows the cross-section of a leaf as it appears using a microscope.

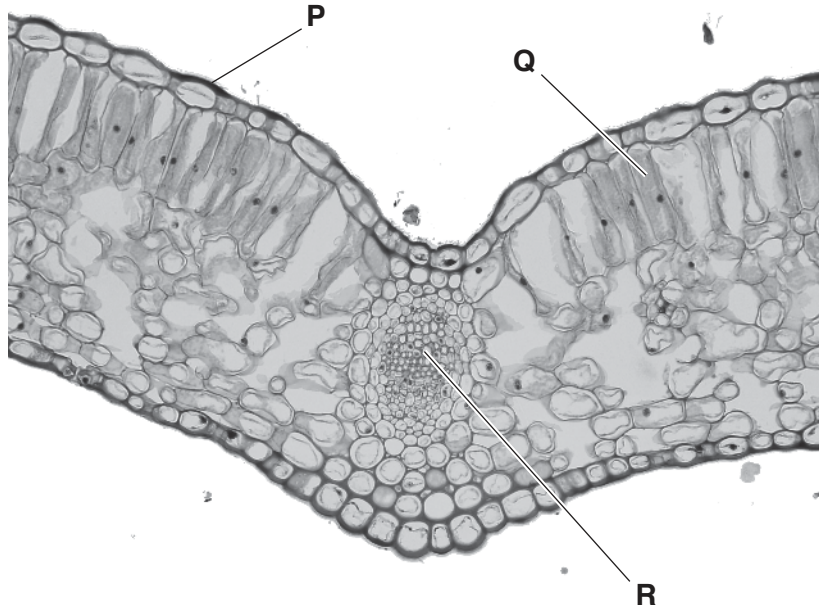

Fig. 13.1

(i) Name the parts of the leaf labelled **P**, **Q** and **R**.

P

Q

R

[3]

(ii) Name a gas that diffuses into the leaf during the day, but diffuses out of the leaf during the night.

..... [1]

(c) The leaf absorbs light energy.

Explain why the cells in the leaf labelled **Q** are good absorbers of this light energy.

.....

 [2]

